

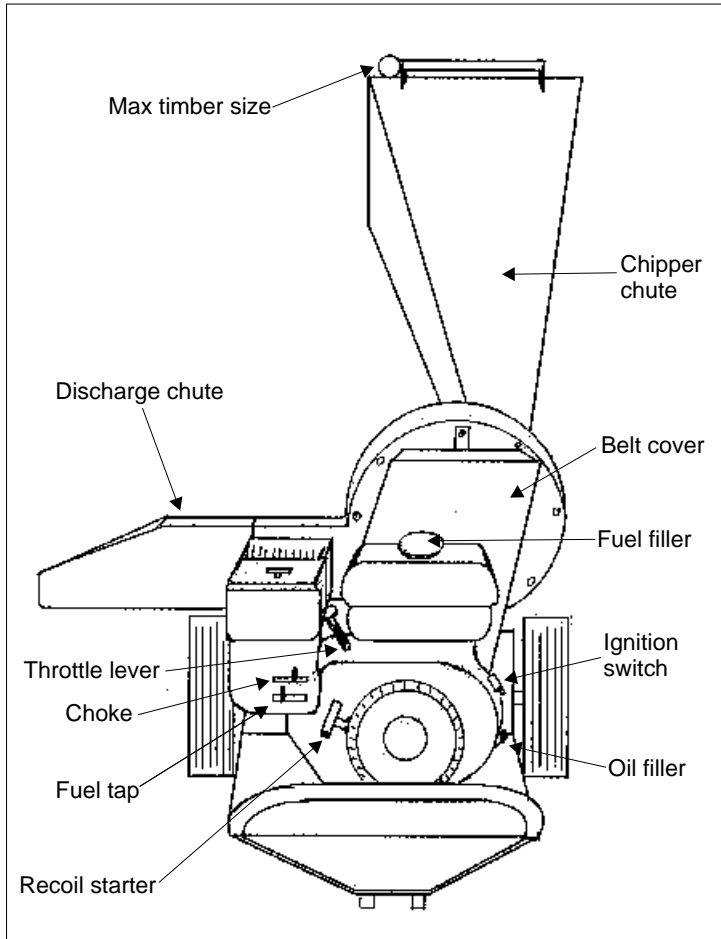

TRACMASTER

Landscape • Groundcare • Conservation



OPERATING INSTRUCTIONS & SAFETY NOTES

CAMON ALL-IN-ONE CHIPPER C50

IMPORTANT	READ CAREFULLY

SOUND LEVEL	
Machine	Sound Level dB(A)
C50 All-in-One Chipper	up to 104.0



Tracmaster Ltd, Teknol House, Victoria Road, Burgess Hill RH15 9LH

Tel: 01444 247689 Fax: 01444 871612

Website: www.tracmaster.co.uk E-mail: info@tracmaster.co.uk



**WEAR EAR
PROTECTION**



**WEAR EYE
PROTECTION**

© Tracmaster Ltd 2006.
Specifications are subject to change without prior notice.
OP/C50/0906

No liability will be accepted for any damage caused to persons or property through failure to observe the operating and safety instructions.

SAFETY

- ALWAYS start the engine in the open air**
- DO NOT smoke when refuelling**
- DO NOT mix OIL with the fuel**
- ALWAYS stop the engine before making any adjustments, refuelling, moving or cleaning, or when the unit is unattended**
- USE ONLY unleaded petrol from fuel containers designed for this purpose - refuel outdoors only and replace the tank cap securely**
- IN CASE of petrol spillage move the machines away from the area of spillage and allow the petrol vapours to dissipate before starting the engine**
- DO NOT remove any safety guards that are fitted**
- DO NOT touch any moving parts or attempt any maintenance whilst the machine is running - KEEP HANDS AND FEET AWAY**
- BEFORE starting work clear the work area of any objects that could damage the machine**
- DO NOT allow children or anyone uninstructed to operate the machine - KEEP ANIMALS AWAY**
- ENSURE the machine is on firm, level ground - DO NOT use machine on a slope**
- ALWAYS wear suitable clothing to give personal protection including footwear that offers a good grip**
- AVOID wearing loose garments that may catch in moving parts**
- KNOW how to stop the machine in an emergency**
- NEVER interfere with any control settings on the engine**
- IF A FAULT develops DO NOT attempt any repair - immediately contact the supplier from whom the machine was obtained**
- VISUALLY INSPECT the machine before use - ensure all nuts and bolts are tight and not worn or damaged**
- KEEP IN MIND the operator is responsible for accidents or hazards occurring to people or property**
- WEAR eye and ear protection**

TO START ENGINE

- Ensure the discharge chute and chipping chute are in the operating position.
- Check the engine oil level. Top up with 10w/40 oil if necessary.
- Check fuel level. Only use unleaded petrol from a clean container. Never re-fuel when the engine is hot or running. Leave 1" air space in the fuel tank.
- Switch on ignition and if the engine is cold, apply the choke.
- Turn the fuel tap to 'on' position and apply half throttle.
- Pull the recoil start handle gently until it engages then give it a good strong pull to start the engine.
- When the engine has started, release the choke lever after a few seconds and return the throttle lever to idle position.

OPERATION

- Increase engine to FULL throttle and allow the machine to build up to its FULL operating speed.
- If you are using the collection bag over the discharge chute then ensure it is not obstructing the exhaust as damage to the bag will occur from a hot exhaust.
- Use the timber sizing ring to ensure the maximum thickness of timber is not exceeded. If the timber does not go through the ring it is too large for the machine to handle.
- Timber less than 1" in diameter usually self-feeds through the machine. If it is over 1" in diameter, it may be necessary to pull the timber back to avoid over-feeding if the engine speed starts to drop.
- Always put the thickest end of the branch into the chute first.
- FAILURE TO OBSERVE THIS PRECAUTION WILL CAUSE DAMAGE** - correct feed pressure and engine speed is important to reduce the possibility of damage to the machine.
- Neither pull out nor push in the short end pieces with hands. Use the next branch to feed the short end through the chipper each time. BE CAREFUL - short ends sometimes feed themselves through the chipper but are occasionally thrown out.
- Never stand on the discharge side of the machine or directly in front of the chipper chute.
- KEEP TO ONE SIDE.

TO STOP ENGINE

- Close the throttle.
- Turn ignition switch to 'OFF' position.
- WARNING: THE EXHAUST COVER MAY BE HOT - DO NOT TOUCH**

MAINTENANCE GUIDE

- For engine maintenance please refer to engine manufacturers manual.
- After every hour of operation:
 - Stop engine. Remove the spark plug cap
 - Check engine oil level. (Recommended oil SAE 10w/40).
 - Do not turn the machine on its side for cleaning.
 - Refit the spark plug cap.

DANGER POINTS TO OBSERVE

- Clear processed material regularly, do not allow it to build up underneath the machine.
- Empty the collection bag regularly if used.
- NEVER overload the machine.
- NEVER stand in front of the chipper chute when the machine is operating.
- NEVER position the machine on a ledge higher or lower than the operator. Machine and operator must be on the same level.
- ALWAYS operate the machine a FULL throttle.
- ALWAYS allow the machine to run at full speed for 2 minutes before switching off.
- Allow the machine to cool down before moving the discharge and infeed chute for transportation.
- WARNING - The exhaust may be hot.
- TURN OFF THE FUEL TAP BEFORE TRANSPORTING THE MACHINE.
- FAILURE TO OBSERVE THESE POINTS MAY RESULT IN PERSONAL INJURY.